

HUAJING GROUP

NO.2 Zong Fu Road, Chengdu 610016 China
Tel: 0086-28-86729898, Fax: 0086-28-86729393
info@durata.com
www.durata.com

HUAJING™

TECHNICAL SPECIFICATION
FOR
ZINC MANGANESE DIOXIDE BATTERIES

DURATA® PLUS

6F22-Aluminum Foil-705



PROMULGATE DATE: January, 2026

SPEC. No.: TS-ZnMn-705

The Manufacturer reserves the right to modify product specification and data stated herein without any prior notice and the right to finally interpret this technical specification.

1. Scope

This specification defines the technical requirements for 6F22 batteries.

Cross Reference:	DURATA	IEC	GB	JIS	ANSI
	705	6F22	6F22	006P	1604D

2. Purpose

To assure that any 6F22 batteries manufactured by DURATA will meet and exceed our customers' expectation.

3. Normative Reference

IEC 60086-1: 2021 *Primary Batteries—Part 1: General*

IEC 60086-2: 2021 *Primary Batteries—Part 2: Physical and Electrical Specifications*

IEC 60086-5:2021 *Primary Batteries—Part 5: Safety of batteries with aqueous electrolyte*

GB 24427-2021 *Content Limitation of mercury, cadmium and lead for anode primary battery*

4. Fundamental Parameter

Item	Data
Item NO.	705
Chemical System	ZINC-MANGANESE DIOXIDE (Ammonium chloride electrolyte)
Primary Component	Zinc, Manganese dioxide, Acetylene black, Ammonium chloride

Item	Data
Nominal Voltage	9 volt
Average Weight	36.5 g
Jacket	Aluminum Foil Jacket
Nominal Capacity	400 mAh ^a
Hazardous Material Content ^b	Hg ≤ 1 ppm, Cd ≤ 20 ppm, Pb ≤ 2000 ppm
Packing	1 pc/blister card ^c

Note:

a) Discharge condition: 620 Ω 2 h/d, end point voltage 4.8 v at 20 ± 2 °C.

b) No Hg, Cd is added in the products during manufacture.

c) We can make various kinds of packages as per the customers' request.

5. Electrical Characteristics

I	Off-load voltage	Acceptance Standard
Initial ^a	9.9 V	GB/T 2828.1-2012 commonly I sampling AQL=0.4
After 12 months	9.6 V	

Note:

a) Initial means that within 60 days after manufacture date, at temperature 20 ± 2 °C, with relative humidity of (55 ± 20)%.

6. Service Time

Discharge Conditions			IEC Standard	MAD ^a	
Discharge load	Daily period	EV V		Initial	After 12months
620 Ω	2 h/d	5.4	24h	28 h	25 h
270 Ω	1 h/d	5.4	7 h	11 h	9.8 h
180 Ω	24 h/d	4.8	/	240 min	200 min
b	c	7.5	8 days	9 days	8 days

Note:

- a) Condition: temperature 20±2 °C, relative humidity (55±20)%.
- b) Background:10 KΩ(smoke detector test), Pulse:620 Ω.
- c) 1 s per hour, 24 h per day.

Explanation:

- 1) The result of the average discharging time under each discharge condition shall be equal to or more than the average minimum time.
- 2) 9 pieces of batteries were tested under each discharge condition.

7. Using Advice

The battery is applicable for high powered digital devices, such as remote control of toys, wireless doorbell, multi-meter etc.

8. Electrolyte Leak Proof Characteristics

Item	Condition	End Period	Result	Acceptance Standard
Over-discharge	180 Ω 24 h/d discharge at 20±2 °C, (55±20)% RH	E.P.V= 3.6 V	There shall be no deformation exceeding the specified dimensions, nor leakage ^a recognized by human eye.	N=8 Ac=0 Re=1
Storage	At temperature 20±2 °C, (55±20)% RH	24 months		Less than 300 ppm

Note:

a) Leakage means unplanned escape of electrolyte, gas or other material from a battery.

9. Safety Characteristics ^a

Item	Test Procedure	End Period	Result	Acceptance Standard
External short circuit	An undischarged battery is directly connected with its positive and negative polarity.	24 h	There shall be no fire and no explosion ^b of battery.	N=5 Ac=0 Re=1

Note:

a) Condition: at temperature 20±2 °C.

10. Caution for Use

- a) Since this battery is non-rechargeable, it is risky if the battery is charged / recharged and it may lead to electrolyte leakage or damage to the device.
- b) The battery should be inserted with regards to polarity (+ and -).
- c) Short circuit, heating, forcing discharging, disposing of in fire, welding/soldering and dismantling the battery are prohibited.
- d) Replace all batteries of a set at the same time. Different electrochemical systems, grades or brands should not be mixed together. Otherwise, it may lead to leakage.
- e) Keep batteries out of the reach of children.
- f) Remove exhausted batteries promptly.

11. Shelf Life and Expiry Date Marking

Shelf Life: 36 months after production under proper storage condition.

Expiry Date Marking: best before date is marked on the bottom of finished cell.

12. Battery Structure (Page 6)

13. Battery Dimension (Page 7)

Battery Structure

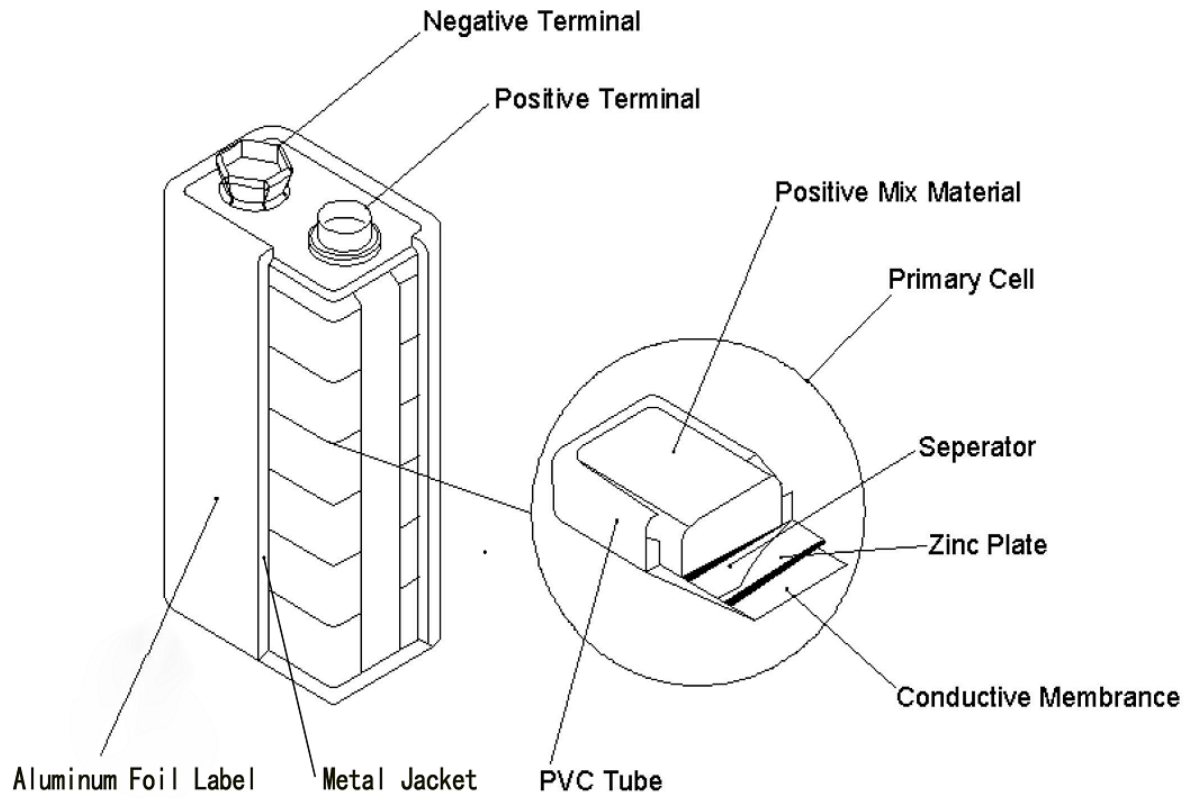

Battery Structure 6F22-Aluminum Foil-705

Battery Dimension

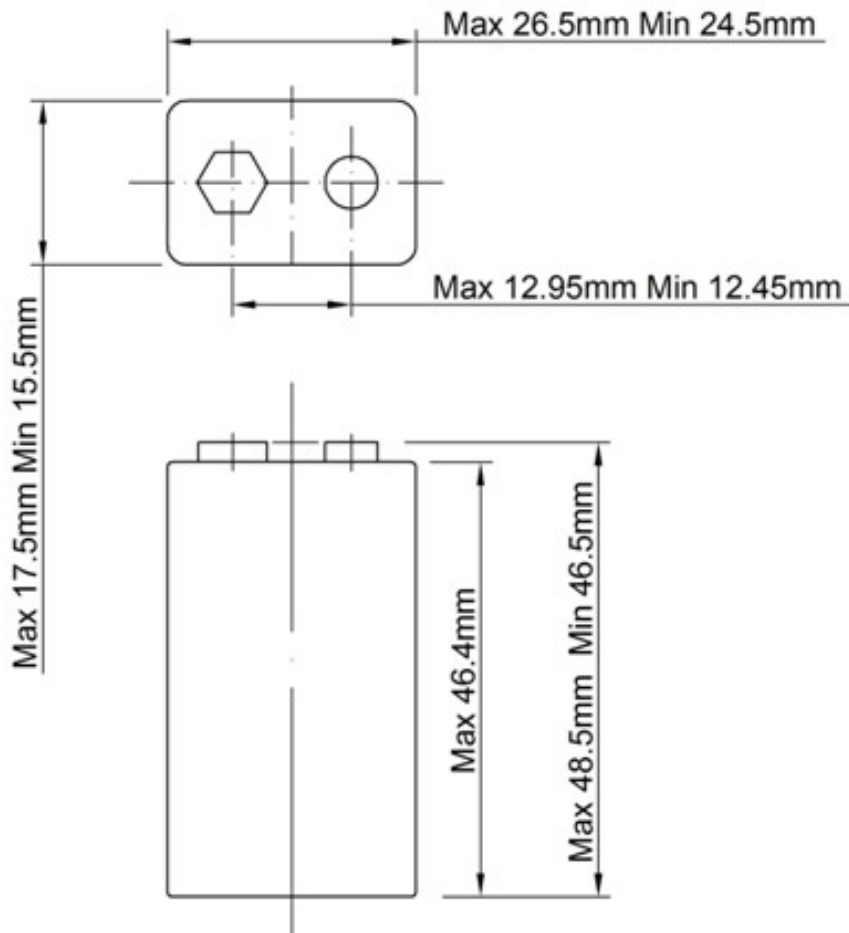

Battery Dimension 6F22-Aluminum Foil -705